

Air Pump

HYDRAULIC PA6D SERIES

6 cu. in./min.
Double-Acting

Compact, lightweight and portable single-speed pump for driving double-acting cylinders.

- Operate at 40-100 psi shop air pressure at the pump.
- Internal relief valve protects circuit components, air inlet filter protects motor.
- Serviceable pump motor is not a “throw away”, providing economical repair.
- Permanently vented reservoir cap.
- dBA 85 at 10,000 psi for all PA6 pumps.

PUMPS

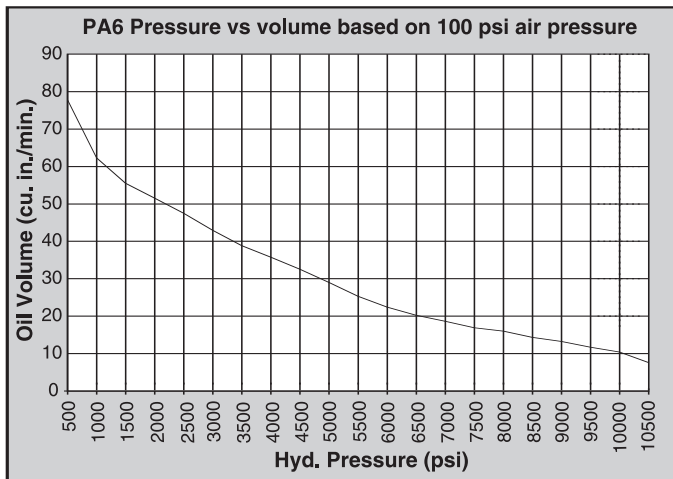

PA6D

10,000 psi

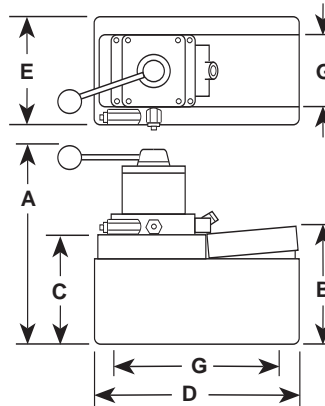

Pump No.	A (in.)	B (in.)	C (in.)	D (in.)	E (in.)	G (in.)
PA6D	10 ³ / ₈	5 ⁷ / ₈	4 ³ / ₈	9 ¹ / ₂	5	4 x 9
PA6DM	10 ³ / ₈	5 ⁷ / ₈	4 ³ / ₈	9 ¹ / ₂	5	4 x 9
PA6DM-1	11	5 ³ / ₄	4 ³ / ₈	12 ⁵ / ₈	7 ³ / ₈	—
PA6D2	12 ³ / ₄	8	7	11 ⁵ / ₁₆	9 ¹ / ₄	5 ¹ / ₈ x 7 ¹ / ₈
PA6DM-2	12 ¹ / ₂	7 ³ / ₄	6 ³ / ₄	11 ¹ / ₂	9 ¹ / ₂	8 x 10



PA6D pump, DG100 digital pressure gauge and 25 ton cylinder used in a test fixture.

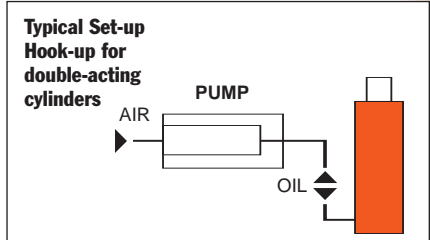

Description	Order No.	Valve No.	Air Supply Req'd (psi)	Reservoir				Prod. Wt (lbs.)
				Cap. (cu. in.)	Usable (cu. in.)	Oil Port (in.)		
Base model pump with high density polyethylene reservoir.	PA6D	9504, 3-way/ 4-way	40-120	105	98	3/8 NPTF	18.4	
PA6D, except has metal reservoir.	PA6DM	9504, 3-way/ 4-way	40-120	105	98	3/8 NPTF	20.4	
PA6D, except has 1 gallon metal reservoir.	PA6DM-1	9504, 3-way/ 4-way	40-120	1 gal.	185	3/8 NPTF	28.1	
PA6D, except has 2 gallon, high density polyethylene reservoir.	PA6D2	9504, 3-way/ 4-way	40-120	2 gal.	454	3/8 NPTF	28.6	
PA6D, except has 2½ gallon metal reservoir.	PA6DM-2	9504, 3-way/ 4-way	40-120	2½ gal.	570	3/8 NPTF	36.2	