

Air Pump

HYDRAULIC PA9 SERIES

9 cu. in./min.
Single-Acting

Ideal for powering single-acting cylinders and portable hydraulic tools.

PUMPS

- Easier to operate than a hand pump, giving you the speed you need at an affordable price.
- Easy and economical to service; not a “throw away” unit.
- Unique bladder design for all-position operation and storage.
- Operates on 40-120 psi shop air, at 20 cfm.
- Hard-coat anodized aluminum housing.
- Oil filler with integral safety relief minimizes chance of damage to reservoir bladder if overfilling occurs.

PA9 Foot Control

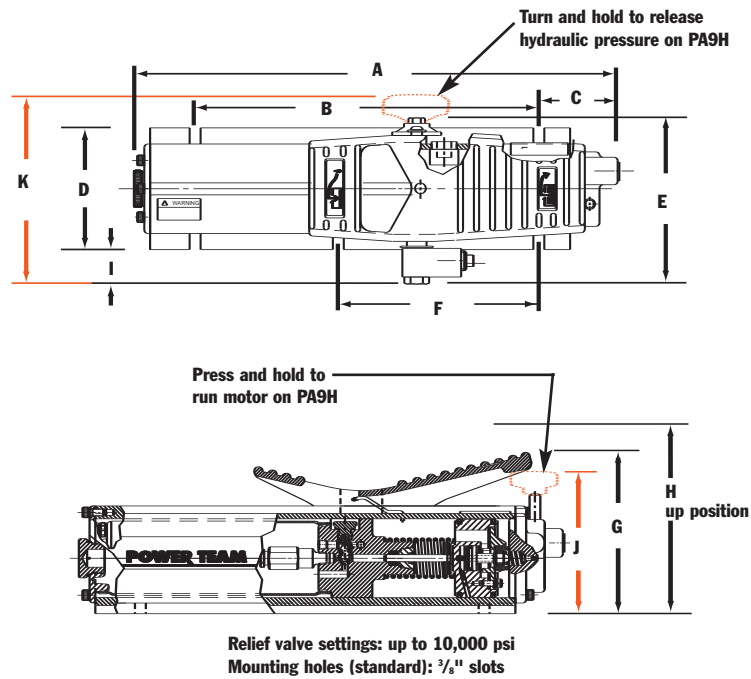

Pump No.	A (in.)	B (in.)	C (in.)	D (in.)	E (in.)	F (in.)	G (in.)	H (in.)	I (in.)	J (in.)	K (in.)
PA9	16 ¹⁵ / ₁₆	12	2 ¹³ / ₁₆	4 ¹ / ₄	5 ⁵ / ₁₆	7	5 ⁵ / ₈	7	1 ¹ / ₈	—	—
PA9H	16 ¹⁵ / ₁₆	12	2 ¹³ / ₁₆	4 ¹ / ₄	—	7	—	7	1 ¹ / ₈	4 ¹³ / ₁₆	6 ¹¹ / ₁₆



PA9
Foot Control



PA9H Hand Control Pump as used in a straightening press.



PA9H
Hand Control

10,000 psi

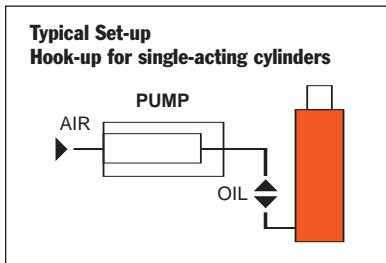
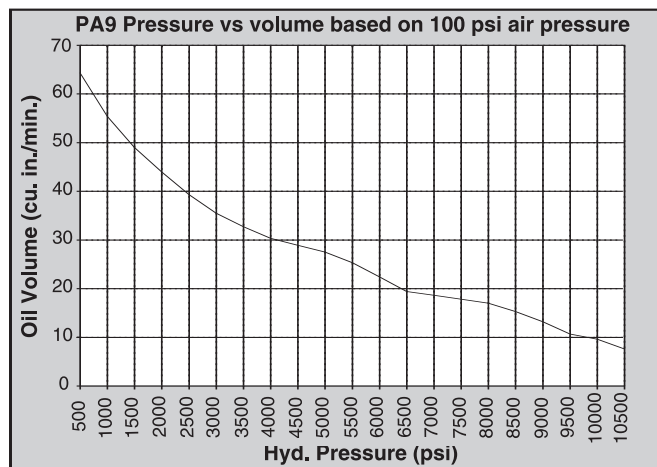

For Use with Cyl. Type	Order No.	Air Supply Req'd (psi)	Reservoir		Oil Port (in.)	Max. Pressure Output (psi)	Prod. Wt. (lbs.)
			Cap. (cu. in.)	Usable (cu. in.)			
Single-Acting	PA9	40-120	35	33.5	3/8 NPTF	10,000	15
Single-Acting	PA9H	40-120	35	33.5	3/8 NPTF	10,000	15

